

Application for City Building Permit

TO THE ENFORCING OFFICER OF NAPOLEON, OHIO

Application No. 361 Date 6-13-60
NAME OF APPLICANT BURL ADERMAN PHONE _____
ADDRESS 609 FIRST ST. NAME and ADDRESS of OWNER SAME

LOCATION OF PROPERTY — LOT NO. 48 IN BARNES 1ST ADDITION
STREET NO. or OTHER DESCRIPTION OF LOCATION 609 FIRST ST.

PRESENT USE OF PROPERTY RESIDENCE PROPOSED USE SAME
ZONING CLASS OF PROPERTY A
CONTRACTOR SELF ADDRESS _____

SHOW ALL DETAILS ON SKETCH BELOW

Estimated Cost 6000⁰⁰
Lot Dimensions 70 x 82.5
Lot Area, Sq. Ft. 5775
Bldg. Size 20 x 26
Sq. Ft. 597
Front Yard 18'
Side Yard 19 + 5 = 24
Off St. Parking 4 x 5
Off St. Loading _____
Type Of Const. FARM
 New Addition
Location Of Sewer or _____
Septic Tank _____
Location Of Water Tap _____

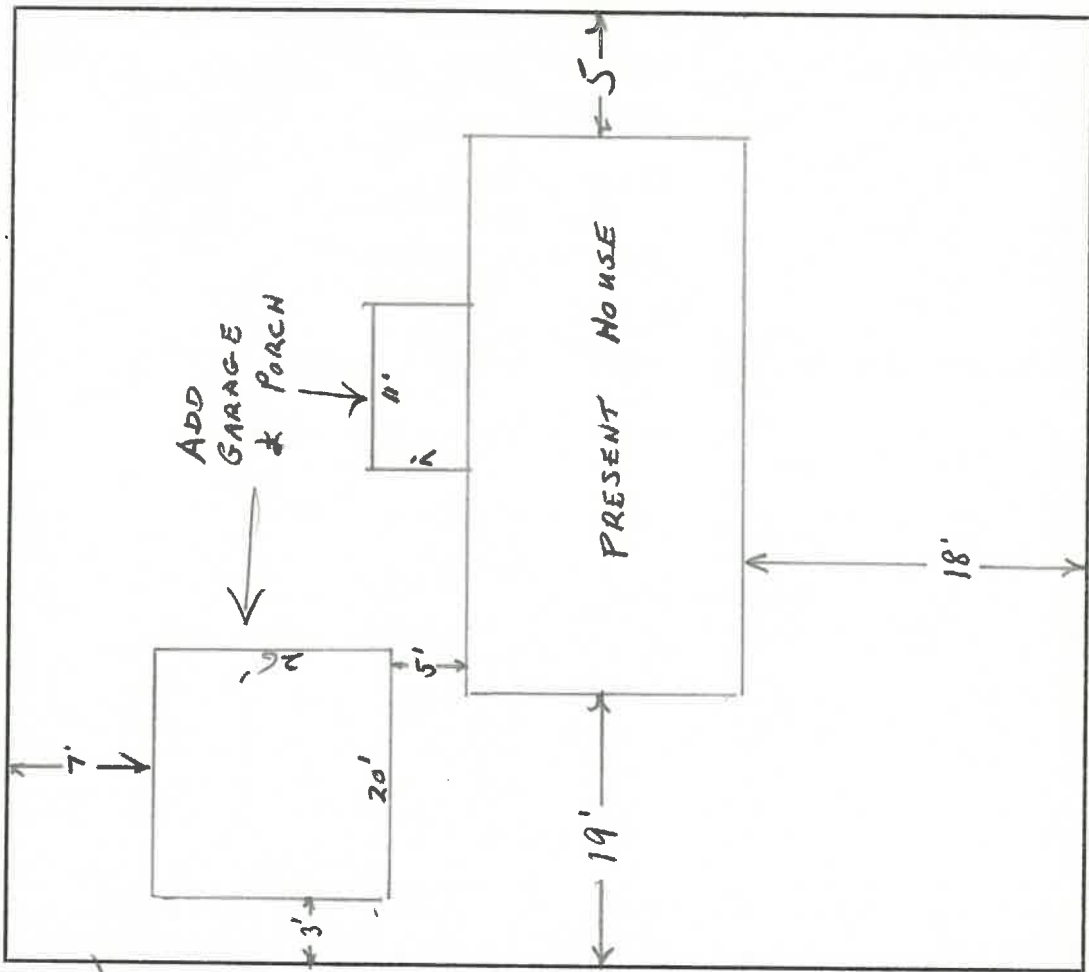

BUILDING PERMIT NO. 361 ISSUED 6-13-60 DENIED _____
IF DENIED, STATE REASONS _____
CERT. OF OCCUPANCY NO. _____ ISSUED _____ INSP. DATE _____
IF DENIED — STATE REASONS _____

BOARD ACTION REQUESTED _____ COMM. ACTION REQUESTED _____

I hereby declare that the above and attached information is correct, and agree, in consideration of and upon issuance of a building permit, to do or allow to be done only such work as herewith applied for and such premises and its existing and proposed buildings and structures shall be used or allowed to be used for such purposes as set forth above.

Signed by Burl Aderman Address _____
who hereby declares that he has been duly authorized by the Owner/Lessee to make the above application and agreement.